

Fluido 110 SYSTEM

- STANDARD
- SELFCLOSE : chiusura automatica / automatic closing
- SINCR0 : apertura e chiusura simultanea / simultaneous opening and closing

SCORREVOLE A SOFFITTO Sliding on Ceiling

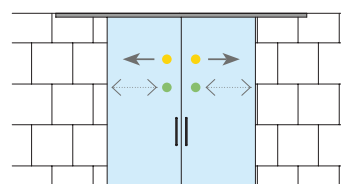
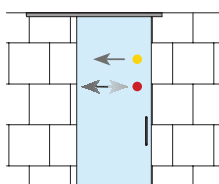
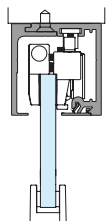

SCORREVOLE A PARETE Sliding on Wall

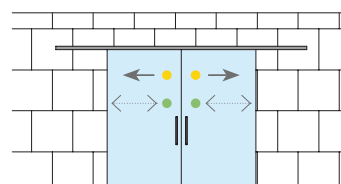
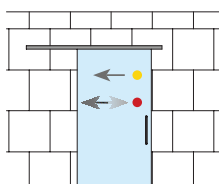
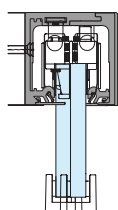

SCORREVOLE SU VETRO FISSO Sliding on Sidelight

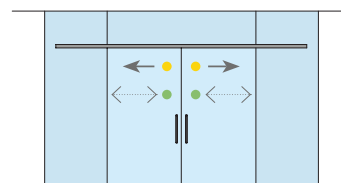
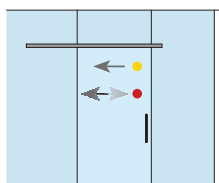
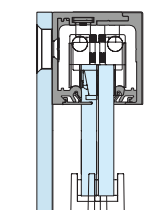

SCORREVOLE A SOFFITTO CON FISSO Sliding on Ceiling with Sidelight

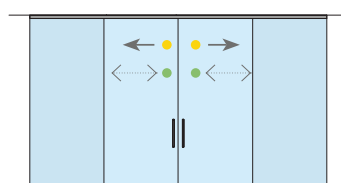
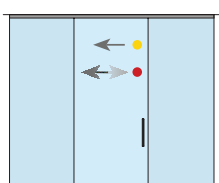
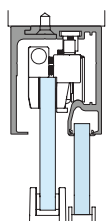

SCORREVOLE A FALSO SOFFITTO Sliding on False Ceiling

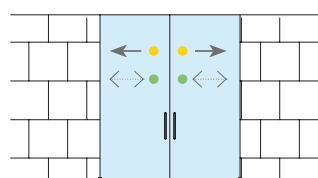
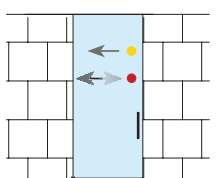
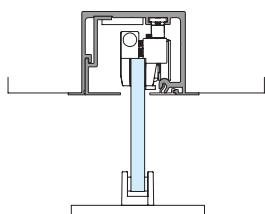

SCORREVOLE A FALSO SOFFITTO CON FISSO Sliding on False Ceiling with Sidelight

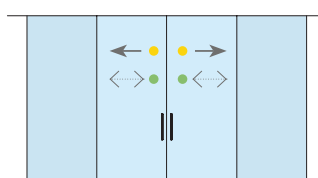
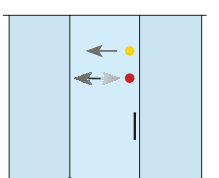
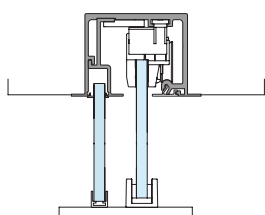

Fluido 110 - Caratteristiche Tecniche Profili

Fluido 110 - Profiles Technical Characteristics

Scorrevole Sliding

(fissaggio a parete - wall mounting)

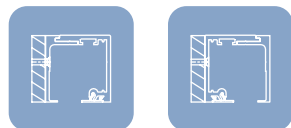

58,5 x 60 mm 58,5 x 60 mm

(fissaggio a soffitto - ceiling mounting)



58,5 x 60 mm

Scorrevole Sliding

(fissaggio a vetro fisso - sidelight mounting)

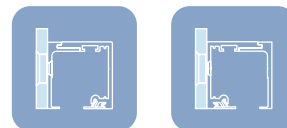

58,5 x 60 mm 58,5 x 60 mm

Scorrevole con vetro fisso

Sliding with sidelight
(fissaggio a soffitto - ceiling mounting)



58,5 x 70 mm

Scorrevole a falso soffitto

Sliding false ceiling



76 x 61 mm

Scorrevole con vetro fisso a falso soffitto















Sliding with sidelight on false ceiling



76 x 61 mm

Dettagli Tecnici

Technical details

 PORTATA Weight	110kg per pannello / for door						
 SPESORE VETRO Glass thickness	10 - 12 - 14 mm						
 REGOLAZIONE IN ALTEZZA Height adjustment	2 mm						
 REVERSIBILITÀ Reversibility	✓						
 DISTANZA A PARETE Wall distance	vetro glass 10 mm 19 mm	vetro glass 12 mm 17 mm	vetro glass 14 mm 15 mm				
 DISTANZA TRA ANTA E VETRO FISSO Distance between door and sidelight	vetro glass 10 mm 12 mm	vetro glass 12 mm 11 mm					
 DISTANZA TRA ANTA E FISSO CON FALSO SOFFITTO Distance between door and sidelight with false ceiling	vetro glass 10 mm 21-19-17 mm	vetro glass 12 mm 19-17-15 mm					
 INSTALLAZIONE A VETRO Glass installation	✓						
 INSTALLAZIONE A FALSO SOFFITTO False ceiling installation	✓						
 SOFTPRO®	Singolo e Doppio / Single and Double						
 DIMENSIONI MINIME (doppio SOFTPRO) Minimum dimensions (double SOFTPRO)	1020 mm						
 ANTISHOCK Antishock	Singolo e Doppio / Single and Double						
 DIMENSIONI MINIME (doppio Antishock) Minimum dimensions (double antishock)	650 mm						
 FINITURE Finishes	Alluminio naturale Aluminum	Simil inox Imitation Satin Stainless Steel					
 CERTIFICAZIONE DURABILITÀ CICLI CORROSIONE Durability certification Corrosion cycles	<div style="display: flex; align-items: center;"> <div style="writing-mode: vertical-rl; transform: rotate(180deg); font-weight: bold; margin-right: 5px;">IN PROCESSO</div> <table border="1" style="margin-left: 10px;"> <tr> <td>EN1527/EN1670</td> </tr> <tr> <td>6</td> </tr> <tr> <td>100.000</td> </tr> <tr> <td>3 (96h)</td> </tr> </table> </div>			EN1527/EN1670	6	100.000	3 (96h)
EN1527/EN1670							
6							
100.000							
3 (96h)							

Fluido 110 SELF CLOSE - Caratteristiche Tecniche Profili

Fluido 110 - Profiles Technical Characteristics

Scorrevole Sliding

(fissaggio a parete - wall mounting)



58,5 x 60 mm

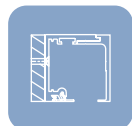

58,5 x 60 mm



58,5 x 60 mm



58,5 x 60 mm

Scorrevole con vetro fisso

Sliding with sidelight

(fissaggio a soffitto - ceiling mounting)



58,5 x 70 mm











(fissaggio a soffitto - ceiling mounting)



58,5 x 60 mm

Dettagli Tecnici

Technical details

 PORTATA Weight	110kg per pannello / for door		
 SPESORE VETRO Glass thickness	10 - 12 - 14 mm		
 REGOLAZIONE IN ALTEZZA Height adjustment	2 mm		
 REVERSIBILITÀ Reversibility	✓		
 DISTANZA A PARETE Wall distance	vetro glass 10 mm 19 mm	vetro glass 12 mm 17 mm	vetro glass 14 mm 15 mm
 DISTANZA TRA ANTA E VETRO FISSO Distance between door and sidelight	vetro glass 10 mm 12 mm	vetro glass 12 mm 11 mm	
 INSTALLAZIONE A VETRO Glass installation	✓		
 SOFTPRO®	Singolo e Doppio / Single and Double		
 DIMENSIONI MINIME (doppio Antishock) Minimum dimensions (double antishock)	1040 mm		
 FINITURE Finishes	Alluminio naturale Aluminum	Simil inox Imitation Satin Stainless Steel	
 CERTIFICAZIONE DURABILITÀ CICLI CORROSIONE Durability certification Corrosion cycles	EN1527/EN1670 6 100.000 3 (96h)		

Fluido 110 SINCRO - Caratteristiche Tecniche Profili

Fluido 110 - Profiles Technical Characteristics

Scorrevole Sliding

(fissaggio a parete - wall mounting)

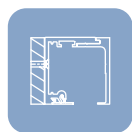

58,5 x 60 mm

(fissaggio a soffitto - ceiling mounting)



58,5 x 60 mm

Scorrevole a falso soffitto

Sliding false ceiling

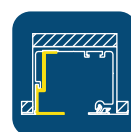

76 x 61 mm

Scorrevole con vetro fisso

Sliding with sidelight

(fissaggio a soffitto - ceiling mounting)



58,5 x 70 mm

Scorrevole con vetro fisso a falso soffitto





Sliding with sidelight on false ceiling



76 x 61 mm

Dettagli Tecnici

Technical details

 PORTATA Weight	110kg per pannello / for door	
 SPESSORE VETRO Glass thickness	10 - 12 mm	
 REGOLAZIONE IN ALTEZZA Height adjustment	2 mm	
 DISTANZA A PARETE Wall distance	30 mm	
 DISTANZA TRA ANTA E VETRO FISSO Distance between door and sidelight	vetro glass 10 mm 12 mm	vetro glass 12 mm 11 mm
 DISTANZA TRA ANTA E FISSO CON FALSO SOFFITTO Distance between door and sidelight with false ceiling	vetro glass 10 mm 21 mm	vetro glass 12 mm 20 mm
 INSTALLAZIONE A VETRO Glass installation	✓	
 INSTALLAZIONE A FALSO SOFFITTO False ceiling installation	✓	
 SOFTPRO®	2 lati/sides 55 kg e 2 lati/sides 110kg	
 DIMENSIONI MINIME Minimum dimensions (2 lati/sides 55 kg SOFTPRO®)	736 mm	
 DIMENSIONI MINIME Minimum dimensions (2 lati/sides 110 kg SOFTPRO®)	1034 mm	
 FINITURE Finishes	Alluminio naturale Aluminum	Simil inox Imitation Satin Stainless Steel
 CERTIFICAZIONE DURABILITÀ CICLI CORROSIONE Durability certification Corrosion cycles	EN1527/EN1670 6 100.000 3 (96h)	

Fluido 110

scorrevole a soffitto - sliding on ceiling

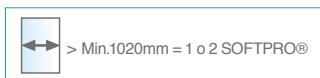

- Profili per scorrevole
- fissaggio a soffitto/parete.
- Perfil para sistema corredero
- fijación a techo/pared.
- Profiles for sliders
- fixed on ceiling/wall.
- Schiebeseystem Fluido
- Befestigung an der Decke.
- Profils pour coulissants
- fixation au plafond

LUNGHEZZE PROFILI

- B110W K41/2 (2mt)
- B110W K41/3 (3mt)
- B110W K41/4 (4mt)
- B110W K41/6 (6mt)

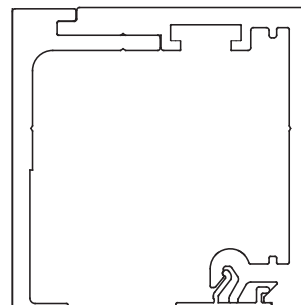

LONGITUDES PERFILES - LENGTH OF PROFILES
PROFILLÄNGE - LONGUEUR DES PROFILS

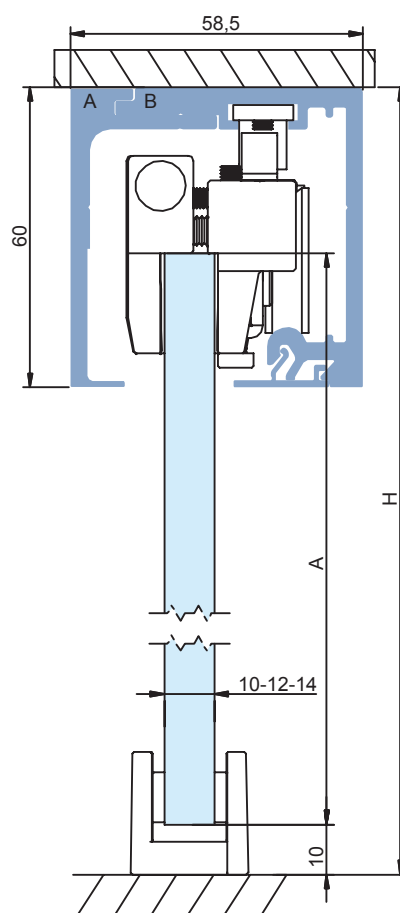
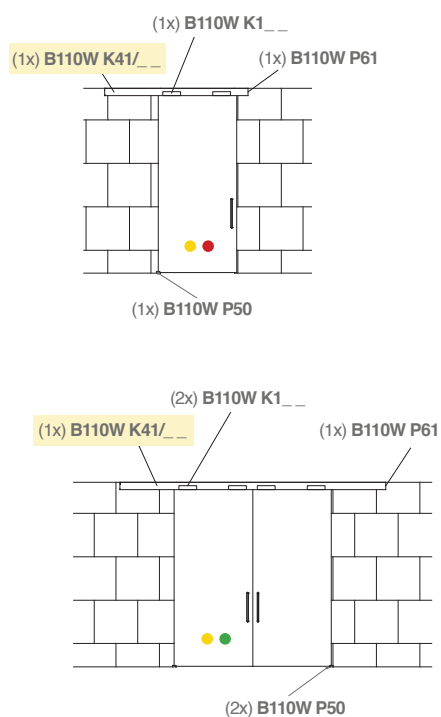

- STANDARD ● SELFCLOSE : chiusura automatica / automatic closing ● SINCR0 : apertura e chiusura simultanea / simultaneous opening and closing

L'installazione dei Fluido 70, 110 e 150 non necessita di forature sul vetro. La instalación del "Fluido 70, 110 y 150" no necesita agujeros en el cristal. The installation of Fluido 70, 110 and 150 does not need holes on the glass. Die Systeme Fluido 70, 110 und 150 benötigen keine Glasbearbeitung. L'installation des coulissants Fluido 70, 110 et 150 ne requiert pas de perçage du verre.

Fluido 110

scorrevole a parete - sliding on wall

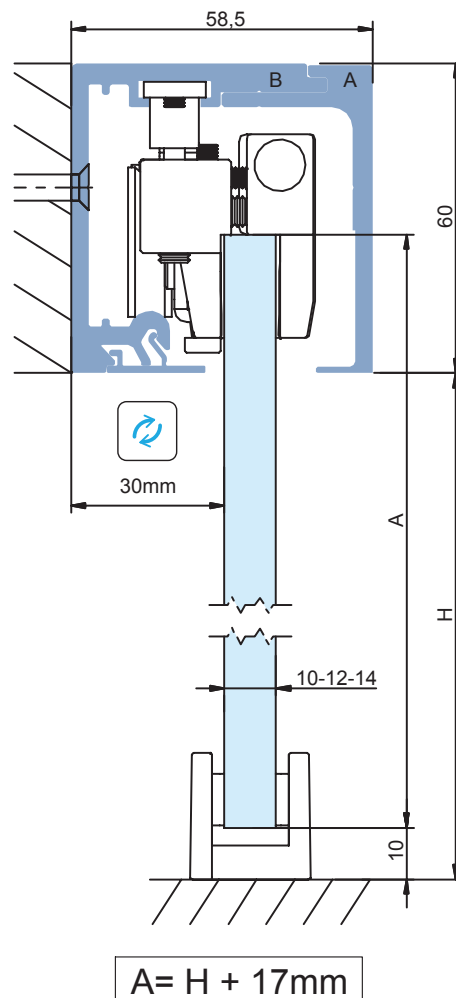
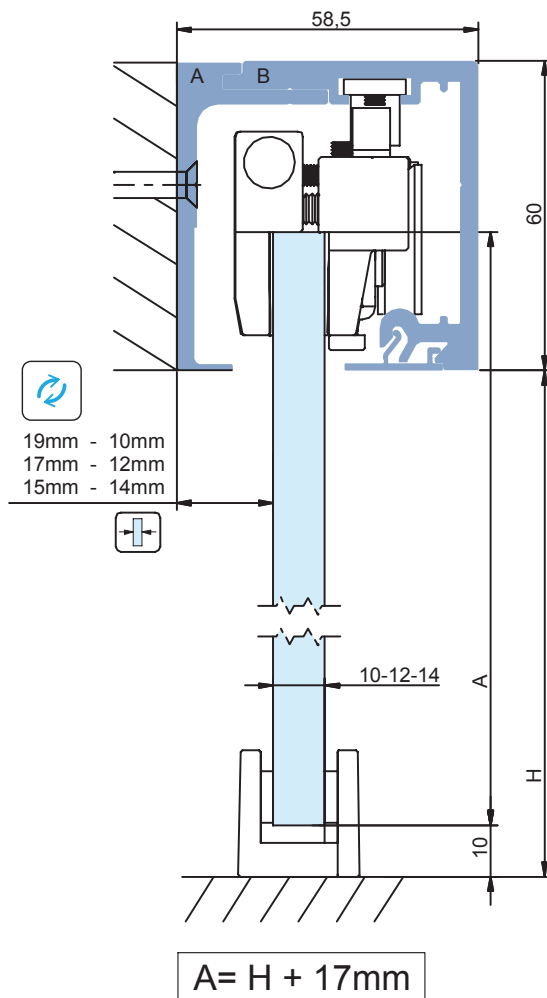
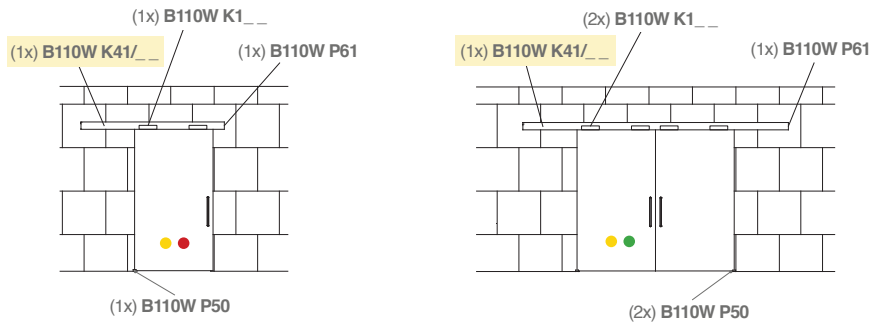

● STANDARD ● SELFCLOSE : chiusura automatica / automatic closing ● SINCR0 : apertura e chiusura simultanea / simultaneous opening and closing

L'installazione dei Fluido 70, 110 e 150 non necessita di forature sul vetro. La instalación del "Fluido 70, 110 y 150" no necesita hojas en el cristal. The installation of Fluido 70, 110 and 150 does not need holes on the glass. Die Systeme Fluido 70, 110 und 150 benötigen keine Glasbearbeitung. L'installation des coulissants Fluido 70, 110 et 150 ne requiert pas de perçage du verre.

Fluido 110

scorrevole su vetro fisso - sliding on sidlight

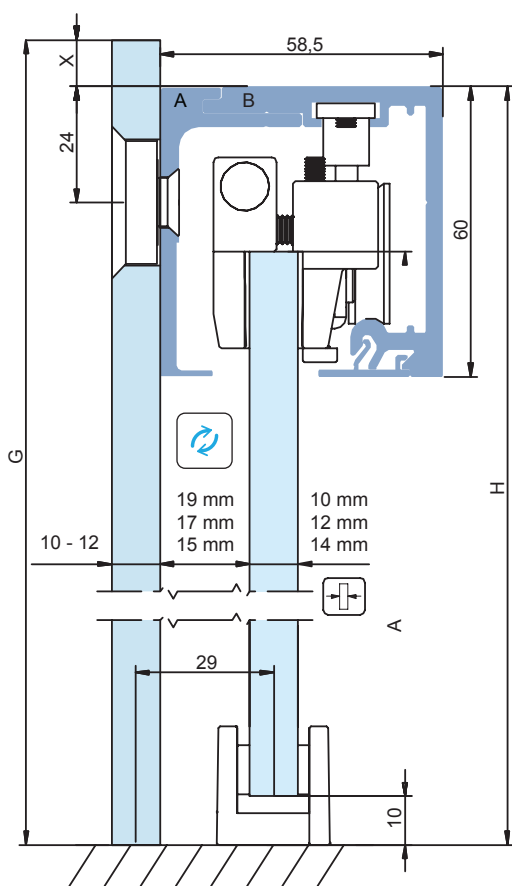
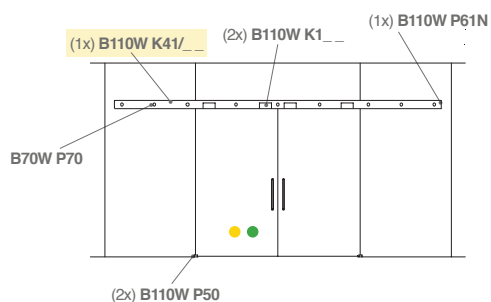
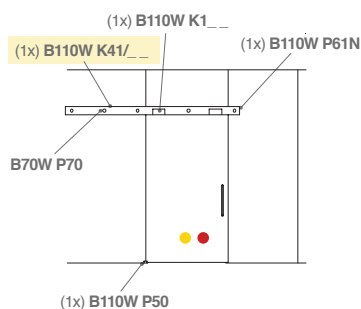

$$A = H - 43 \text{ mm}$$

$$G = H + X$$

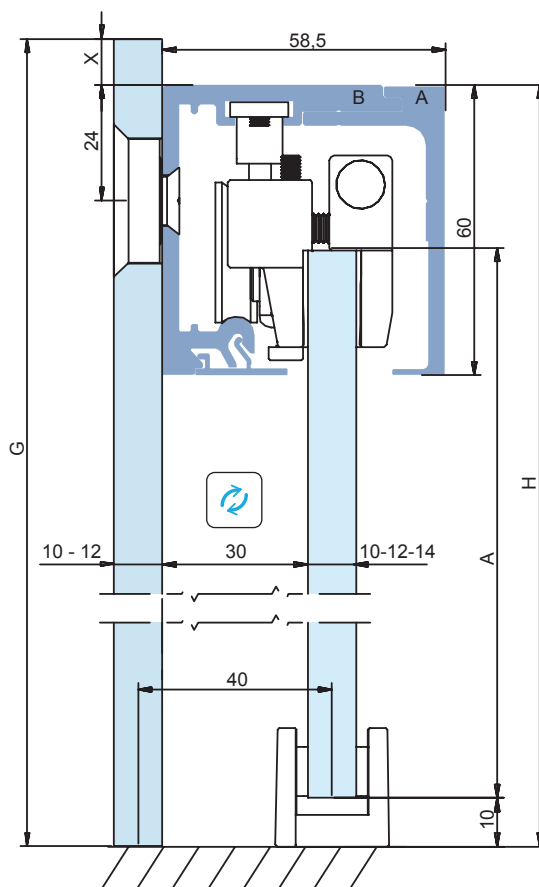

$$A = H - 43 \text{ mm}$$

$$G = H + X$$

● STANDARD ● SELF-CLOSE : chiusura automatica / automatic closing ● SINCRO : apertura e chiusura simultanea / simultaneous opening and closing

L'installazione del Fluido 70, 110 e 150 non necessita di forature sul vetro. La instalación del "Fluido 70, 110 y 150" no necesita agujeros en el cristal. The installation of Fluido 70, 110 and 150 does not need holes on the glass. Die Systeme Fluido 70, 110 und 150 benötigen keine Glasbearbeitung. L'installation des coulissants Fluido 70, 110 et 150 ne requiert pas de perçage du verre.

Fluido 110

scorrevole a soffitto con fisso - sliding on ceiling with sidelight

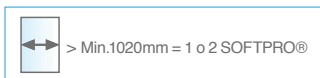

- Kit profili per scorrevole
- fissaggio a soffitto con vetro fisso.
- Kit perfil para sistema corredero - fijación a techo con vidrio fijo.
- Kit profiles for sliders – fixed on ceiling with fixed glass.
- Profil-Set für Schiebeseystem – Befestigung an der Decke mit Glasseiteenteil.
- Kit profils pour portes coulissantes - fixation au plafond avec verre fixe.

LUNGHEZZE PROFILI

- B110W K43/2 (2mt)
- B110W K43/3 (3mt)
- B110W K43/4 (4mt)
- B110W K43/6 (6mt)

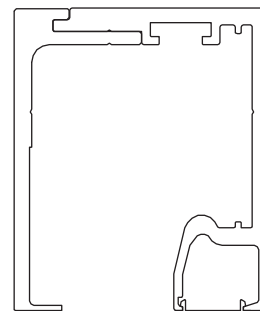

LONGITUDES PERFILES - LENGTH OF PROFILES
PROFILLÄNGE - LONGUEUR DES PROFILS

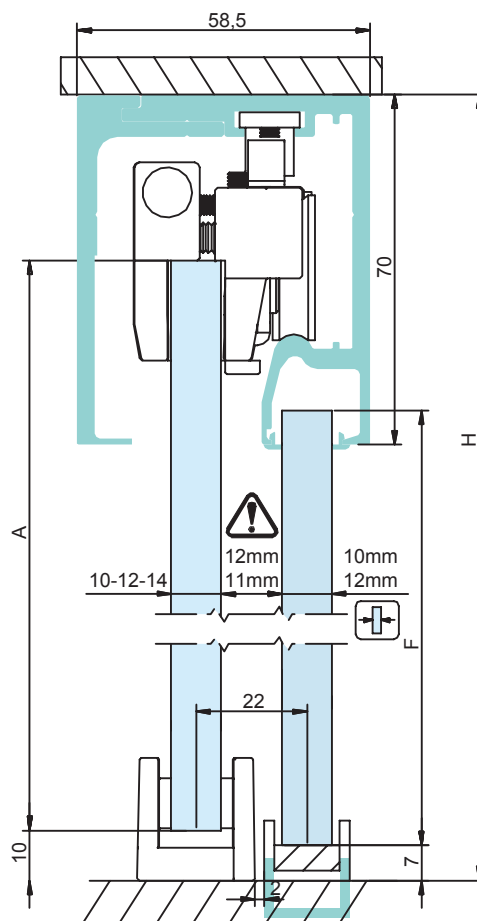
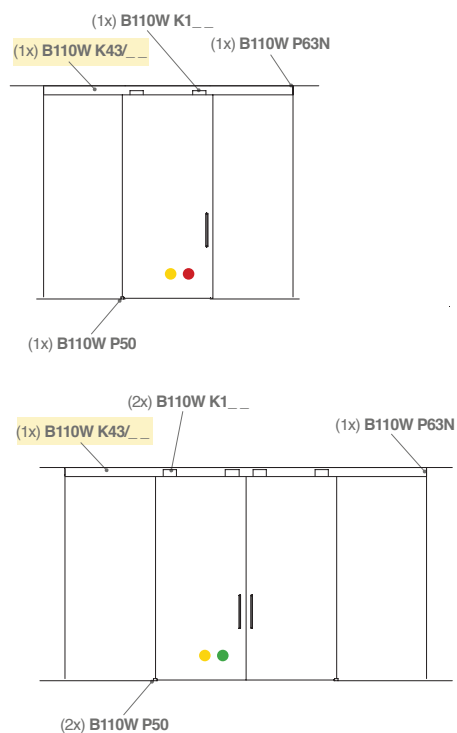

$$A=H - 43\text{mm}$$

$$F=H - 70\text{mm}$$

- STANDARD ● SELFCLOSE : chiusura automatica / automatic closing ● SINCR0 : apertura e chiusura simultanea / simultaneous opening and closing

L'installazione del Fluido 70, 110 e 150 non necessita di forature sul vetro. La instalación del "Fluido 70, 110 y 150" no necesita agujeros en el cristal. The installation of Fluido 70, 110 and 150 does not need holes on the glass. Die Systeme Fluido 70, 110 und 150 benötigen keine Glasbearbeitung. L'installation des coulissants Fluido 70, 110 et 150 ne requiert pas de perçage du verre.

Fluido 110

scorrevole a falso soffitto - sliding on false ceiling

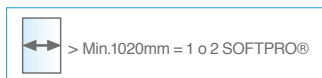

- Profili per scorrevole
- fissaggio a falso soffitto.
- Perfil para sistema corredero
- fijación a cielo falso.
- Kit profiles for sliders
- fixed on false ceiling.
- Profil für Schiebeseystem
- Befestigung an abgehängter Decke.
- Profils pour portes coulissantes
- fixation sur faux-plafond.

LUNGHEZZE PROFILI

- B110W K44/2 (2mt)
- B110W K44/3 (3mt)
- B110W K44/4 (4mt)
- B110W K44/6 (6mt)

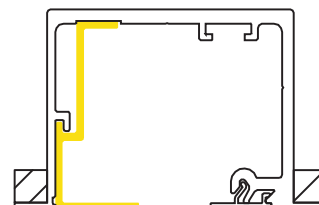

LONGITUDES PERFILES - LENGTH OF PROFILES
PROFILLÄNGE - LONGUEUR DES PROFILS

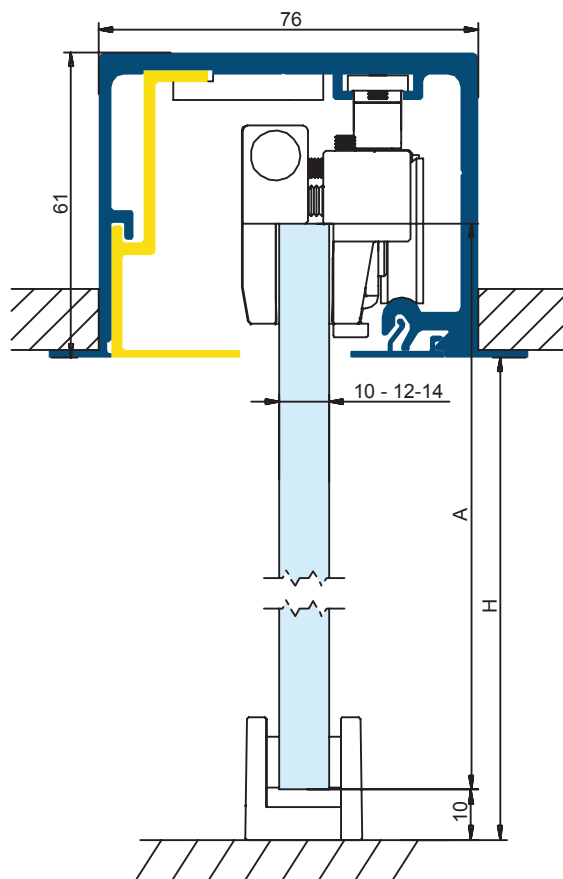
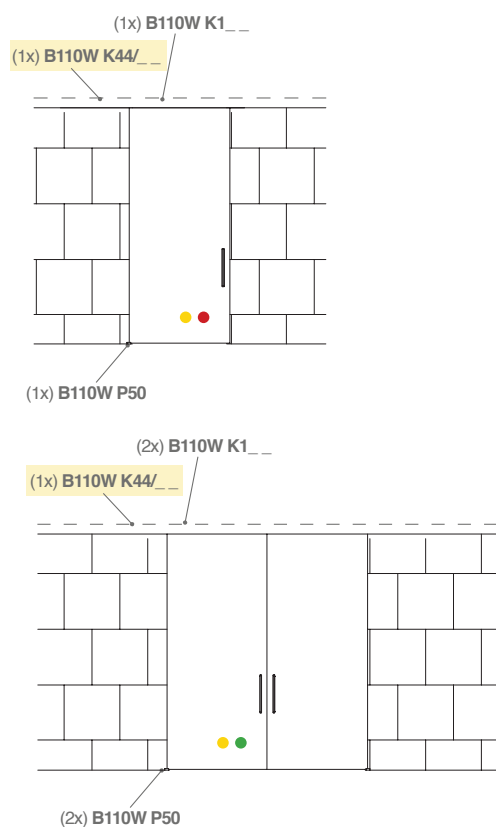

$$A = H + 17\text{mm}$$

- STANDARD ● SELFCLOSE : chiusura automatica / automatic closing ● SINCR0 : apertura e chiusura simultanea / simultaneous opening and closing

L'installazione dei Fluido 70, 110 e 150 non necessita di forature sul vetro. La instalación del "Fluido 70, 110 y 150" no necesita agujeros en el cristal. The installation of Fluido 70, 110 and 150 does not need holes on the glass. Die Systeme Fluido 70, 110 und 150 benötigen keine Glasbearbeitung. L'installation des coulissants Fluido 70, 110 et 150 ne requiert pas de perçage du verre.

Fluido 110

scorrevole a falso soffitto con fisso - sliding on false ceiling with sidelight

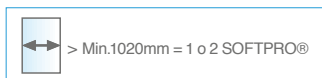

- Profili per scorrevole
- fissaggio a falso soffitto con vetro fisso.
- Perfil para sistema correrer
- fijación a cielo falso con vidrio fijo.
- Profiles for sliders
- fixed on false ceiling with fixed glass.
- Profil für Schiebeseystem - Befestigung an abgehängter Decke mit Glasseitenteil.
- Profils pour coulissants
- fixation faux-plafond avec verre fixe.

LUNGHEZZE PROFILI

- B170W K45/2 (2mt)
- B170W K45/3 (3mt)
- B170W K45/4 (4mt)
- B170W K45/6 (6mt)

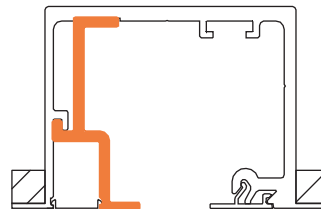

LONGITUDES PERFILES - LENGTH OF PROFILES
PROFILLÄNGE - LONGUEUR DES PROFILS

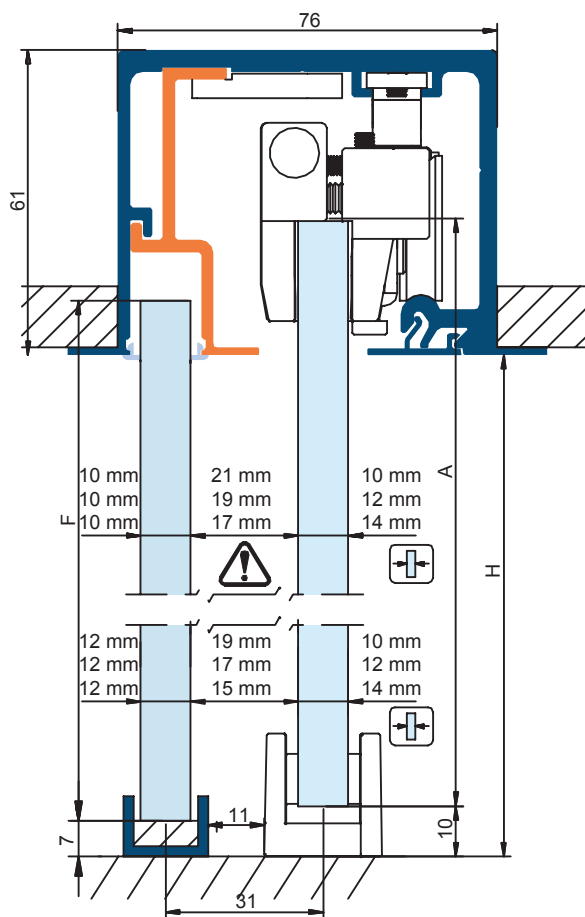
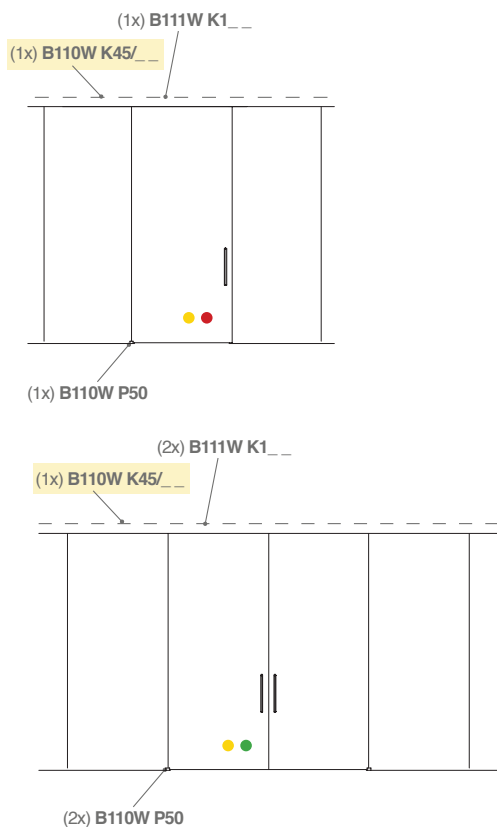

$$A = H + 17 \text{ mm}$$

$$F = H + 4$$

- STANDARD ● SELFCLOSE : chiusura automatica / automatic closing ● SINCRO : apertura e chiusura simultanea / simultaneous opening and closing

L'installazione dei Fluido 70, 110 e 150 non necessita di forature sul vetro. La instalación del "Fluido 70, 110 y 150" no necesita hojas en el cristal. The installation of Fluido 70, 110 and 150 does not need holes on the glass. Die Systeme Fluido 70, 110 und 150 benötigen keine Glasbearbeitung. L'installation des coulissants Fluido 70, 110 et 150 ne requiert pas de perçage du verre.

Fluido 110 - KIT PINZE STANDARD

Standard clamps kit - for Fluido 110

B110W K1NN

- Kit 2 pinze + 2 fermi meccanici.
- Kit 2 pinzas + 2 topes mecánicos.
- Kit 2 clamps + 2 mechanical stops.
- Set mit 2 Laufwagen + 2 Endanschlägen.
- Kit 2 pinces + 2 freins mécaniques.

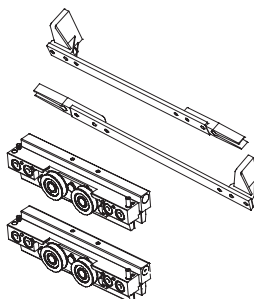

B110W K1NA

- Kit 2 pinze + 1 fermo meccanico + 1 Anti-Schok.
- Kit 2 pinzas + 1 tope mecánico + 1 Anti-Schok.
- Kit 2 clamps + 1 mechanical stop + 1 Anti-Shock.
- Set mit 2 Laufwagen + 1 Endanschlag + 1 Endstopper.
- Kit 2 pinces + 1 frein mécanique + 1 anti-schoc.

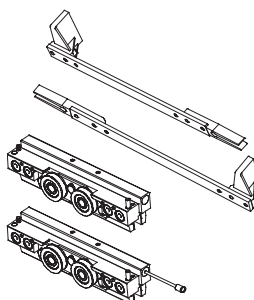

B110W K1NS

- Kit 2 pinze + 1 fermo meccanico + 1 SOFTPRO®.
- Kit 2 pinzas + 1 tope mecánico + 1 SOFTPRO®.
- Kit 2 clamps + 1 mechanical stop + 1 SOFTPRO®.
- Set mit 2 Laufwagen + 1 Endanschlag + 1 SOFTPRO®.
- Kit 2 pinces + 1 frein mécanique + 1 SOFTPRO®.

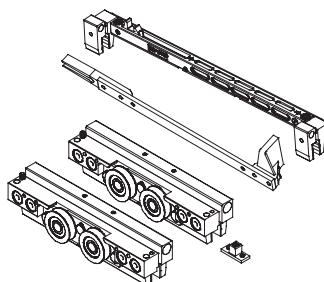

B110W K1AA

- Kit 2 pinze + 2 Anti-Schok.
- Kit 2 pinzas + 2 Anti-Schok.
- Kit 2 clamps + 2 Anti-Shocks.
- Set mit 2 Laufwagen + 2 Endstoppern.
- Kit 2 pinces + 2 anti-choc.

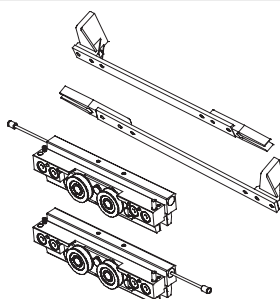

B110W K1AS

- Kit 2 pinze + 1 Anti-Schok + 1 SOFTPRO®.
- Kit 2 pinzas + 1 Anti-Schok + 1 SOFTPRO®.
- Kit 2 clamps + 1 Anti-Shock + 1 SOFTPRO®.
- Set mit 2 Laufwagen + 1 Endstopper + 1 SOFTPRO®.
- Kit 2 pinces + 1 anti-choc + 1 SOFTPRO®.

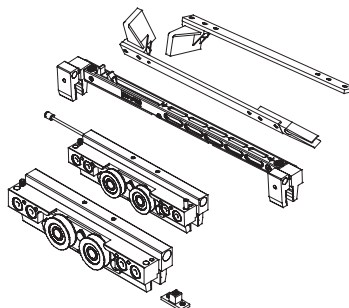

B110W K1SS

- Kit 2 pinze + 2 SOFTPRO®.
- Kit 2 pinzas + 2 SOFTPRO®.
- Kit 2 clamps + 2 SOFTPRO®.
- Set mit 2 Laufwagen + 2 SOFTPRO®.
- Kit 2 pinces + 2 SOFTPRO®.

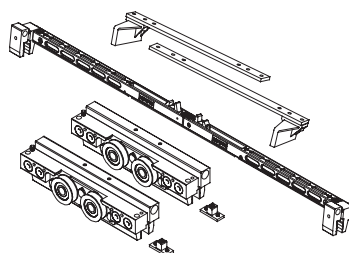

Fluido110 - KIT ACCESSORI SINCRO e SELF CLOSE

Sincro & Selfclose accessories set - for Fluido 110

B110SW K1SS SINCRO ●

- Set di accessori SINCRO. SOFTPRO® 2 lati 110 kg.
- Kit accesorios SINCRO - SOFTPRO® en ambos lados 110 kg.
- Set of accessories SINCRO. SOFTPRO® 2 sides 110 kg.
- Set mit Zubehör SINCRO. SOFTPRO 2 Seiten 110 kg.
- Kit accessoires SINCRO. SOFTPRO 2 côtés 110 kg.

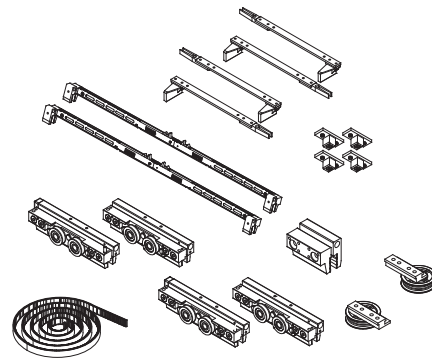

B110SW K1NS SINCRO ●

- Set di accessori SINCRO. SOFTPRO® 2 lati 55 kg.
- Kit accesorios SINCRO - SOFTPRO® en ambos lados 55 kg.
- Set of accessories SINCRO. SOFTPRO® 2 sides 55 kg.
- Set mit Zubehör SINCRO. SOFTPRO 2 Seiten 55 kg.
- Kit accessoires SINCRO. SOFTPRO 2 côtés 55 kg.

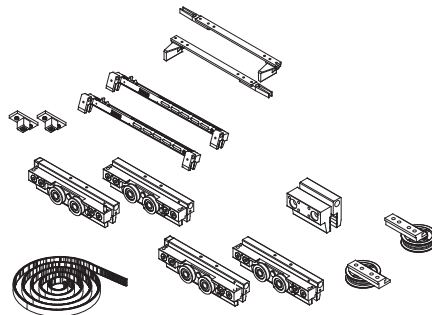

B110SW K1NN SINCRO ●

- Set di accessori SINCRO. 2 fermi meccanici.
- Kit accesorios SINCRO - 2 topes mecánicos.
- Set of accessories SINCRO. 2 stops.
- Set mit Zubehör SINCRO. 2 Endanschlägen.
- Kit accessoires SINCRO. 2 freins mécaniques.

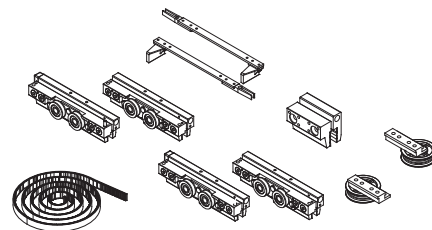

B110CW K1NS SELF CLOSE ●

- Set di accessori SELF CLOSE.
1 SOFTPRO® + Freno di ritenzione.
- Kit accesorios SELF CLOSE.
1 SOFTPRO® + 1 freno retenedor.
- Set of accessories SELF CLOSE.
1 SOFTPRO® + Retention brake.
- Set mit Zubehör SELF CLOSE
1 SOFTPRO + Haltebremse.
- Kit accessoires SELF CLOSE.
1 SOFTPRO+ frein de rétention.

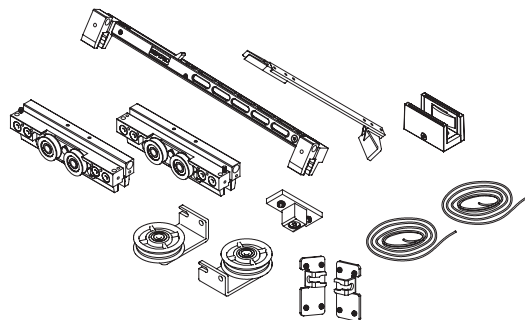

B110CW K1SS SELF CLOSE ●

- Set di accessori SELF CLOSE + SOFTPRO® doppio.
- Kit accesorios SELF CLOSE + doble SOFTPRO®.
- Set of accessories SELF CLOSE + double SOFTPRO®.
- Set mit Zubehör SELF CLOSE + doppeltes SOFTPRO®.
- Kit accessoires SELF CLOSE. + double SOFTPRO.

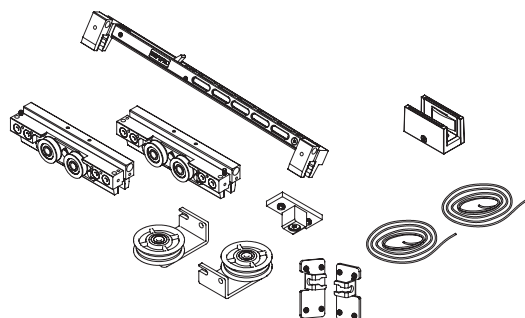

Fluido110 - COMPONENTI

Components - for Fluido 110

B110W P50

- Guida a terra.
- Guía al suelo.
- Floor track.
- Bodenführung.
- Rail de sol.



B110W P61

x B110W K41

- Coppia di tappi.
- Pareja de tapones.
- Pair of caps.
- Paar Endkappen.
- Paire de capots.

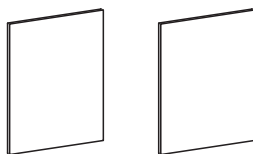

B110W P63

x B110W K43

- Coppia di tappi.
- Pareja de tapones.
- Pair of caps.
- Paar Endkappen.
- Paire de capots.

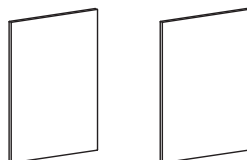

B70W P70

- Borchia per fissaggio barra a vetro.
- Tornillo para ajuste de la barra a vidrio.
- Stud to fix glass bar.
- Befestigung für Laufschiene an Glas.
- Point ponctuel de fixation.



Lunghezza barra

Longitud de la barra
Bar length
Profillänge
Longueur de barre

Quantità borchie

Cantidad tornillos
Quantity of studs
Anzahl der Stifte
Quantité

2 mt	10
2,5 mt	13
3 mt	15
5 mt	25